

NOTES - EXISTING EASEMENTS

- 9 A GRANT OF EASEMENT DATED NOVEMBER 2, 1972 EXECUTED BY AND BETWEEN COLLINS RADIO COMPANY, DON KOLL COMPANY, INC AND KOLL CENTER NEWPORT AS SET FORTH IN SECTION 1.04, 1.05 (A PORTION THEREOF), 1.06, 1.08, 1.10 AND 1.11 RECORDED NOVEMBER 6, 1972 IN BOOK 10413, PAGE 573 OF OFFICIAL RECORDS.
- 12 AN EASEMENT FOR POLE LINES, CONDUITS AND INCIDENTAL PURPOSES IN FAVOR OF SOUTHERN CALIFORNIA EDISON RECORDED AS BOOK 11074, PAGE 182 OF OFFICIAL RECORDS.
- 15 AN EASEMENT FOR POLE LINES, CONDUITS AND INCIDENTAL PURPOSES IN FAVOR OF SOUTHERN CALIFORNIA EDISON RECORDED AS BOOK 11077, PAGE 1117 OF OFFICIAL RECORDS.
- 16 A NON-EXCLUSIVE EASEMENT FOR PURPOSES OF INGRESS AND EGRESS AS RESERVED IN THE DEED RECORDED MAY 7, 1974 IN BOOK 11137, PAGE 1008 OF OFFICIAL RECORDS OVER A PORTION OF SAID PARCEL B-1.
- 18 AN EASEMENT FOR STORM DRAIN AND INCIDENTAL PURPOSES IN FAVOR OF KOLL CENTER NEWPORT, A LIMITED PARTNERSHIP, RECORDED AS BOOK 11137, PAGE 1020 OF OFFICIAL RECORDS.
- 23 AN EASEMENT FOR ELECTRICAL SUPPLY AND COMMUNICATIONS SYSTEMS AND INCIDENTAL PURPOSES IN FAVOR OF SOUTHERN CALIFORNIA EDISON RECORDED MARCH 7, 1990 AS INSTRUMENT NO. 90-120897 OF OFFICIAL RECORDS.
- 24 AN EASEMENT FOR COMMUNICATION FACILITIES AND INCIDENTAL PURPOSES IN FAVOR OF PACIFIC BELL RECORDED JULY 3, 1991 AS INSTRUMENT NO. 91-346219 OF OFFICIAL RECORDS.
- 25 AN EASEMENT FOR MAINTENANCE AND OPERATION OF AN ELECTRICAL SUBSTATION AND INCIDENTAL PURPOSES IN FAVOR OF SOUTHERN CALIFORNIA EDISON RECORDED SEPTEMBER 3, 1992 AS INSTRUMENT NO. 92-594041 OF OFFICIAL RECORDS.
- 29 AN EASEMENT FOR TELECOMMUNICATIONS FACILITIES AND INCIDENTAL PURPOSES IN FAVOR OF COXCOM INC., D/B/A COX COMMUNICATIONS ORANGE COUNTY, RECORDED NOVEMBER 15, 2005 AS INSTRUMENT NO. 2005000916240 OF OFFICIAL RECORDS.
- 30 GRANT AND QUITCLAIM OF EASEMENTS FOR PASSAGE INCLUDING THE RIGHT TO MAINTAIN DRIVEWAYS, ROADWAYS, SIDEWALKS AND PASSAGEWAYS RECORDED MAY 26 1978 IN BOOK 12690 PAGE 854 OF OFFICIAL RECORDS.

ACREAGES

| LOT NO. | AREA AC | LOT AC | AREA LAND USE: |
|---------|---------|--------|--|
| 1 | 0.96 | A | 0.11 OPEN SPACE, PUBLIC ACCESS & UTILITY EASEMENT |
| 2 | 0.67 | B | 0.04 LANDSCAPE & UTILITY EASEMENT |
| 3 | 1.29 | C | 0.03 LANDSCAPE & UTILITY EASEMENT |
| 4 | 1.03 | D | 0.03 LANDSCAPE & UTILITY EASEMENT |
| 5 | 1.34 | E | 0.03 PUBLIC ACCESS, SIGNAGE, LANDSCAPE, UTILITY, PEDESTRIAN & BICYCLE EASEMENT |
| 6 | 0.97 | F | 0.04 PUBLIC ACCESS, SIGNAGE, LANDSCAPE, UTILITY, PEDESTRIAN & BICYCLE EASEMENT |
| 7 | 0.74 | G | 0.04 PUBLIC ACCESS, SIGNAGE, LANDSCAPE, UTILITY, PEDESTRIAN & BICYCLE EASEMENT |
| 8 | 0.82 | H | 0.12 PUBLIC ACCESS, SIGNAGE, LANDSCAPE, UTILITY, PEDESTRIAN & BICYCLE EASEMENT |
| 9 | 1.58 | I | 0.14 PUBLIC ACCESS, SIGNAGE, LANDSCAPE, UTILITY, PEDESTRIAN & BICYCLE EASEMENT |
| 10 | 0.30 | J | 0.18 PUBLIC ACCESS, SIGNAGE, LANDSCAPE, UTILITY, PEDESTRIAN & BICYCLE EASEMENT |
| 11 | 1.18 | K | 0.10 PUBLIC ACCESS, SIGNAGE, LANDSCAPE, UTILITY, PEDESTRIAN & BICYCLE EASEMENT |
| 12 | 1.91 | L | 0.03 PUBLIC ACCESS, SIGNAGE, LANDSCAPE, UTILITY, PEDESTRIAN & BICYCLE EASEMENT |
| 13 | 0.94 | M | 1.02 PARK |
| 14 | 1.06 | N | 0.15 PUBLIC ACCESS, LANDSCAPE & UTILITY EASEMENT |
| 15 | 1.54 | O | 1.03 PARK |
| 16 | 0.78 | P | 0.10 OPEN SPACE, PUBLIC ACCESS & UTILITY EASEMENT |
| 17 | 0.67 | Q | 1.76 ROAD WAY & UTILITY EASEMENT |
| | | R | 0.04 ROAD WAY, UTILITY, PEDESTRIAN & BICYCLE EASEMENT |
| | | S | 0.25 OPEN SPACE, PUBLIC ACCESS & UTILITY EASEMENT |
| | | T | 0.48 ROAD WAY & UTILITY EASEMENT |
| | | U | 0.04 ROAD WAY, UTILITY, LANDSCAPE, PEDESTRIAN & BICYCLE EASEMENT |
| | | V | 0.62 ROAD WAY & UTILITY EASEMENT |
| | | W | 0.03 OPEN SPACE & PUBLIC ACCESS |
| | | X | 0.04 OPEN SPACE & PUBLIC ACCESS |
| | | Y | 0.10 OPEN SPACE, PUBLIC ACCESS & UTILITY EASEMENT |
| | | Z | 0.36 OPEN SPACE, PUBLIC ACCESS & UTILITY EASEMENT |
| | | AA | 0.11 OPEN SPACE, PUBLIC ACCESS & UTILITY EASEMENT |
| | | BB | 0.23 PRIVATE ACCESS FOR LOT 11 & 12 |

GROSS AREA: 25.05 AC
 LESS ROADWAY, PARKWAY, SIDEWALK: 4.54 AC
 LESS PARK: 2.05 AC
 NET DEVELOPABLE AREA: 18.46 AC

TENTATIVE TRACT MAP NO. 17438

IN THE CITY OF NEWPORT BEACH, COUNTY OF ORANGE, STATE OF CALIFORNIA
 FOR CONDOMINIUM PURPOSES

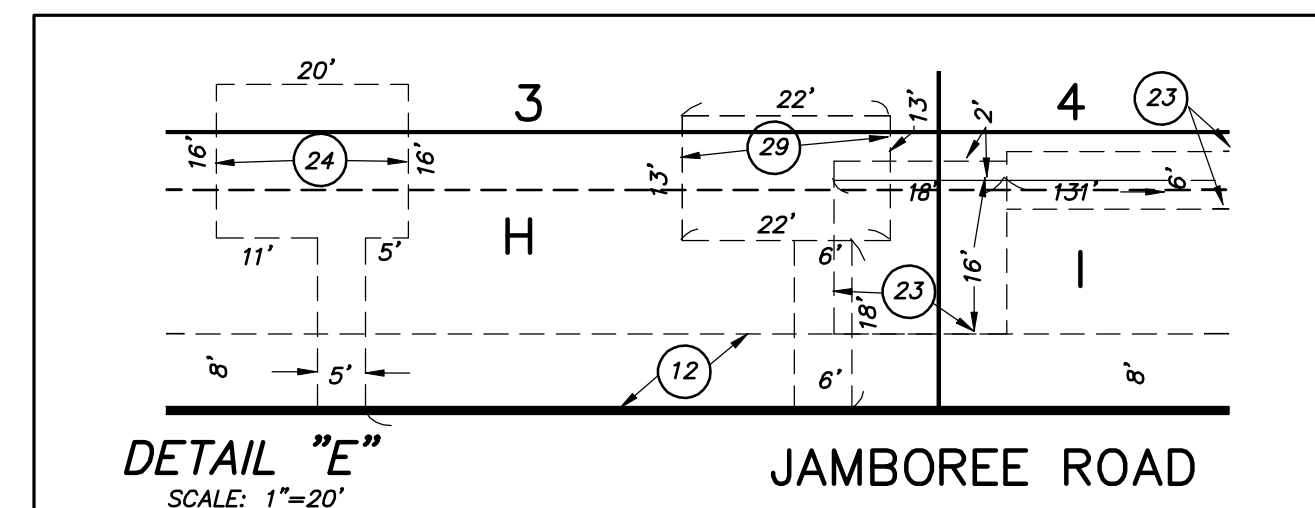

GENERAL NOTES

- GROSS AREA: 25.05 ACRES
- THE PROJECT IS WITHIN THE FEDERAL EMERGENCY MANAGEMENT AGENCY'S CLEAR ZONE Z, AREA OF 500-YEAR FLOOD ON THE FLOOD INSURANCE RATE MAP (FIRM), COMMUNITY PANELMAP NO. 0286, EFFECTIVE DATE: FEBRUARY 18, 2004.
- THIS TENTATIVE MAP MAY HAVE MULTIPLE FINAL MAPS.
- THOSE EXISTING EASEMENTS OR PORTIONS OF EXISTING EASEMENTS AFFECTING THE PROPERTY WITHIN THE BOUNDARY OF THIS MAP WILL BE QUITCLAIMED TO THE EXTENT NECESSARY TO ACCOMMODATE THE FUTURE LAND USE.
- ON SITE SEWER AND STORM DRAIN WILL BE PRIVATE.
- PUBLIC ANGLED PARKING AND PEDESTRIAN ACCESS RIGHTS ALONG INTERNAL PRIVATE ROADWAYS WILL BE DOCUMENTED WITH THE CC&R'S.
- ALL SIDEWALKS, ANGLED PARKING AND PARKWAY WILL BE PRIVATE WITH PRIVATE MAINTENANCE.
- STREETS TO BE PRIVATE AND PRIVATELY MAINTAINED.

OWNER/SUBDIVIDER

UPTOWN NEWPORT LP
 C/O SHOPOFF MANAGEMENT, INC.
 2 PARK PLAZA, SUITE 700
 IRVINE, CA 92614
 (949) 231-5068
 (949) 417-1399 FAX

LEGEND

- DIRECTION OF DRAINAGE FLOW
- FF = FINISHED FLOOR
- PE = PAD ELEVATION
- PE1 = PAD ELEVATION WITH 1 LEVEL OF PARKING BELOW GRADE
- PE2 = PAD ELEVATION WITH 2 LEVELS OF PARKING BELOW GRADE
- TENTATIVE TRACT BOUNDARY
- PROPOSED LOT LINE
- PROPOSED BUILDING PAD
- 56- PROPOSED GRADE CONTOUR
- ROADWAY CENTERLINE

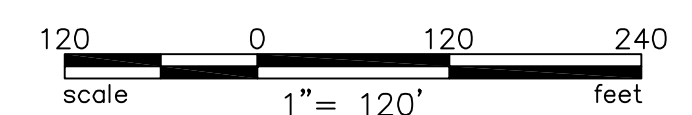
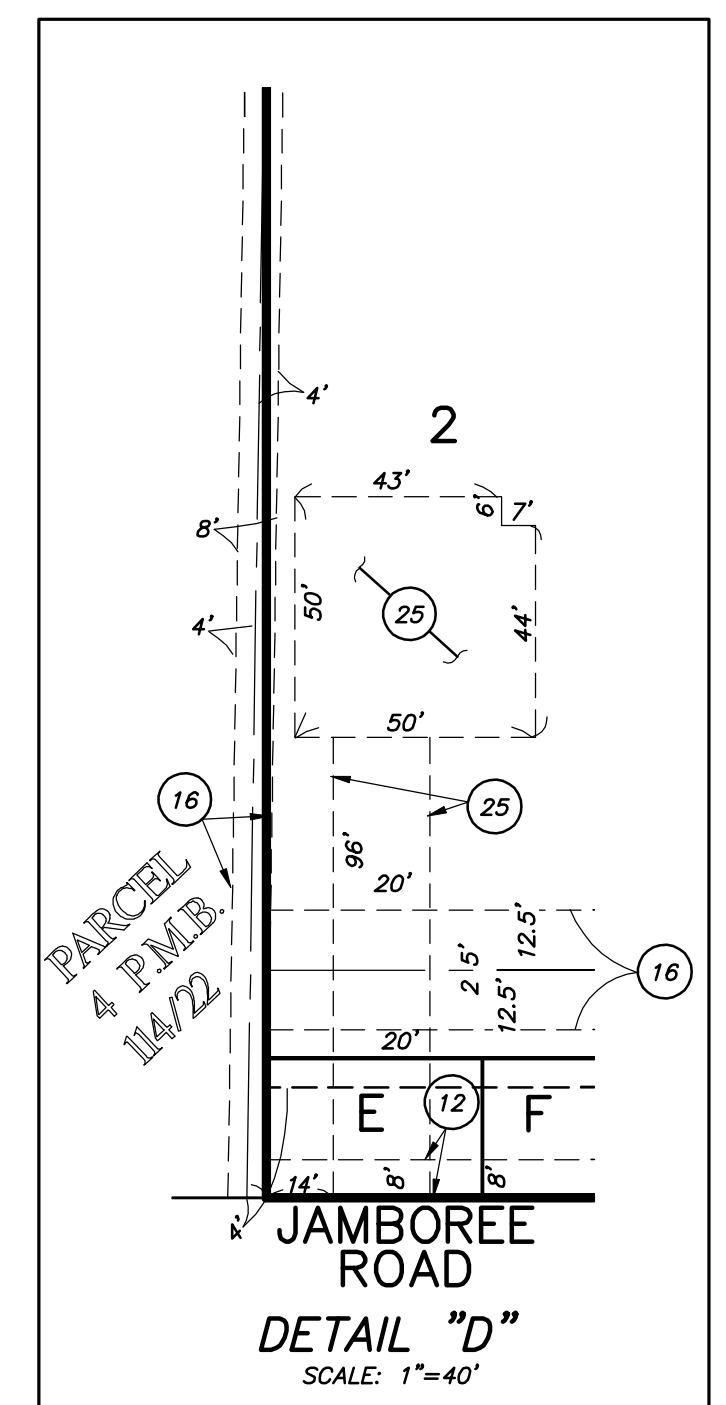
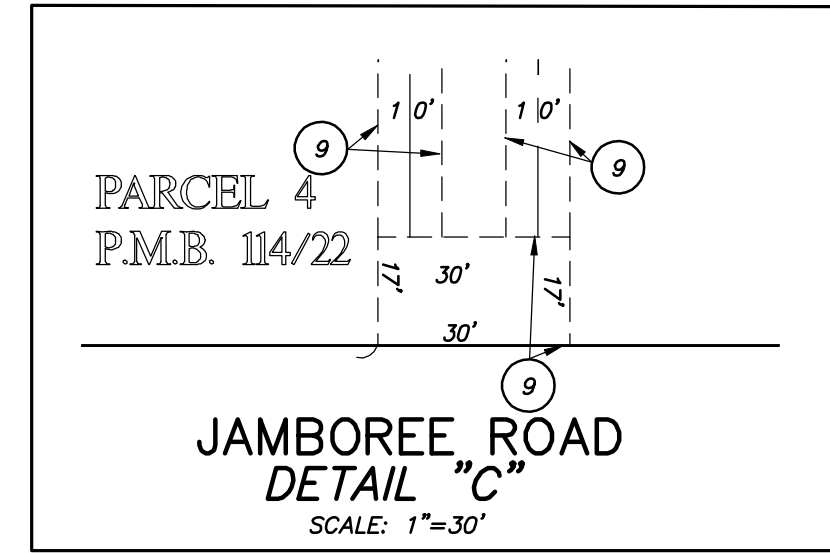
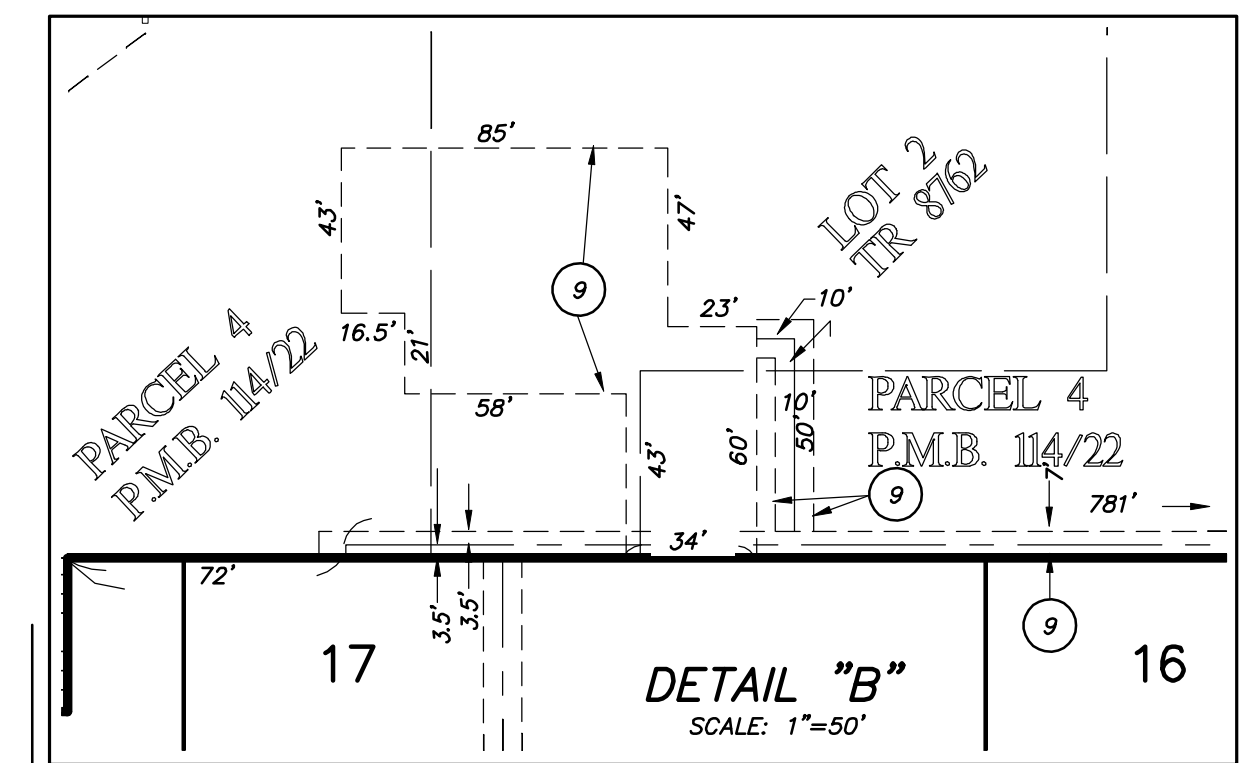
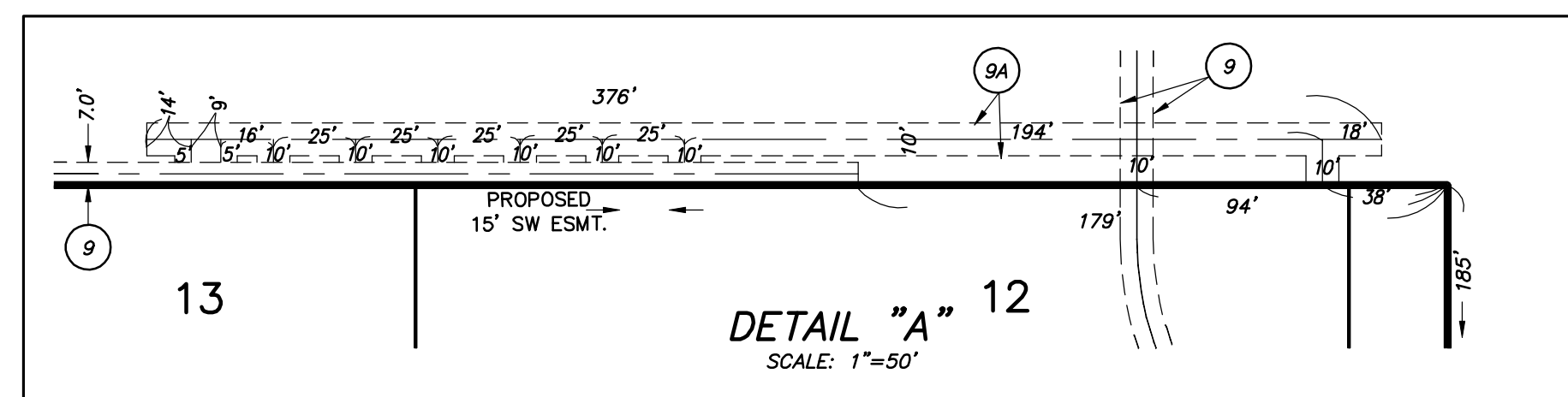
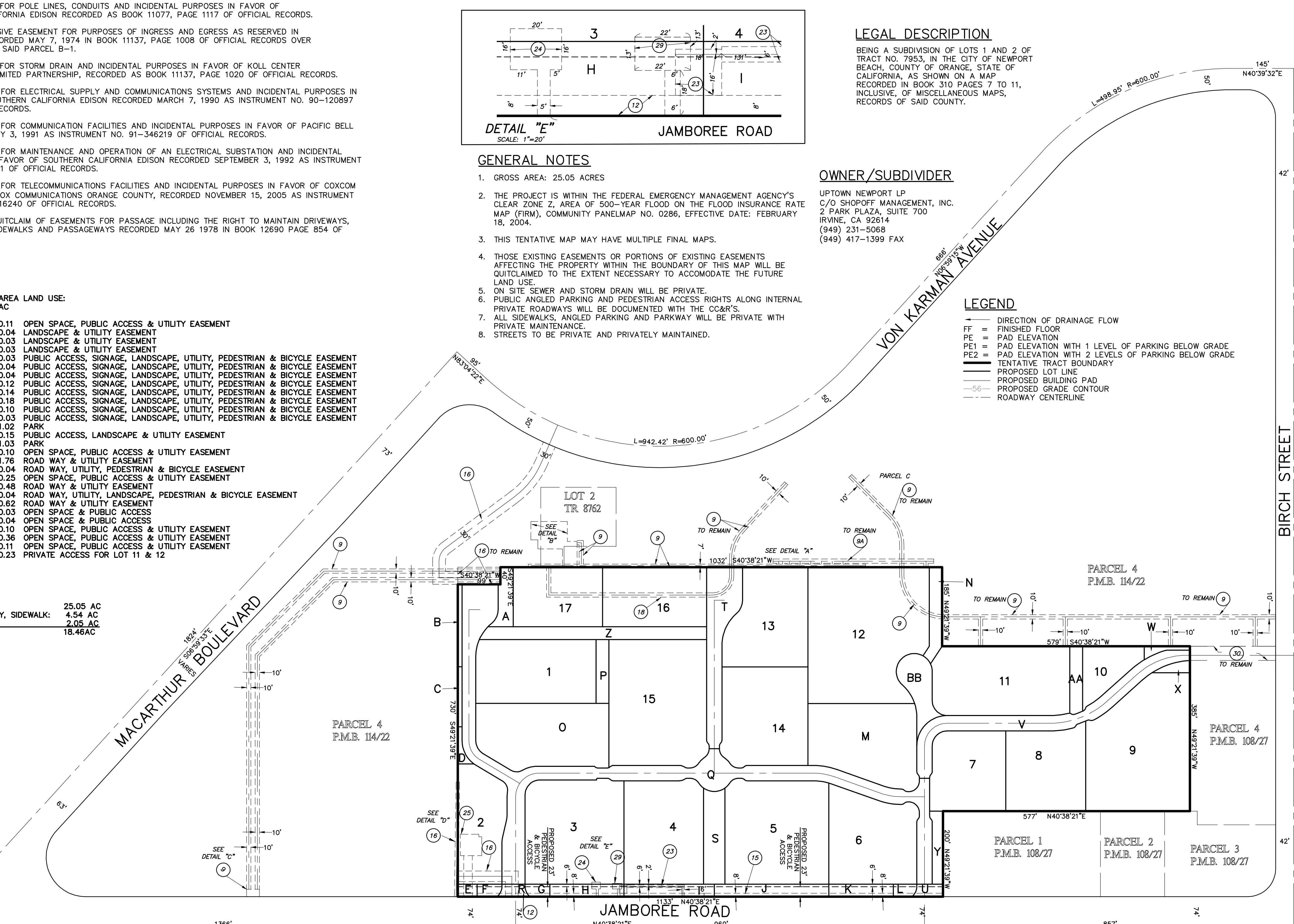

| NO. | DESCRIPTION | DATE | BY |
|-----------|-------------|------|----|
| REVISIONS | | | |



Hall & Foreman, Inc.
 Engineering • Planning • Surveying
 17782 17TH ST, SUITE 200 • TUSTIN, CA 92780-1947 • 714-665-4500
 PREPARED UNDER THE SUPERVISION OF: JOHN C. HOGAN 11/27/12 DATE

CITY OF NEWPORT BEACH
 TENTATIVE TRACT MAP 17438
 APN: 445-131-02 & -03
 UPTOWN NEWPORT
 PA2011-134

FILE NO.
 DRAWING NO.
 SHEET
1 OF 2

SCALE: 1"=120'
 DATE: 11/28/12
 DRAWN BY: CS & EO
 DESIGNED BY: JA & EO

Drawing Name: C:\Users\jforan\My Documents\Map\17-100286T1.dwg Tbl: Paper
 Date: 11/28/12 10:56am by: cforan

TENTATIVE TRACT MAP NO. 17438

IN THE CITY OF NEWPORT BEACH, COUNTY OF ORANGE, STATE OF CALIFORNIA
FOR CONDOMINIUM PURPOSES

| CURVE | RADIUS | LENGTH |
|-------|---------|---------|
| C1 | 30.00' | 27.53' |
| C2 | 30.00' | 27.72' |
| C3 | 30.00' | 27.40' |
| C4 | 67.00' | 62.98' |
| C5 | 132.00' | 45.06' |
| C6 | 182.00' | 29.01' |
| C7 | 182.00' | 94.41' |
| C8 | 175.00' | 127.95' |
| C9 | 218.00' | 89.77' |
| C10 | 218.00' | 40.37' |
| C11 | 218.00' | 49.40' |
| C12 | 212.00' | 22.01' |
| C13 | 10.00' | 7.52' |
| C14 | 10.01' | 8.06' |
| C15 | 40.00' | 12.77' |

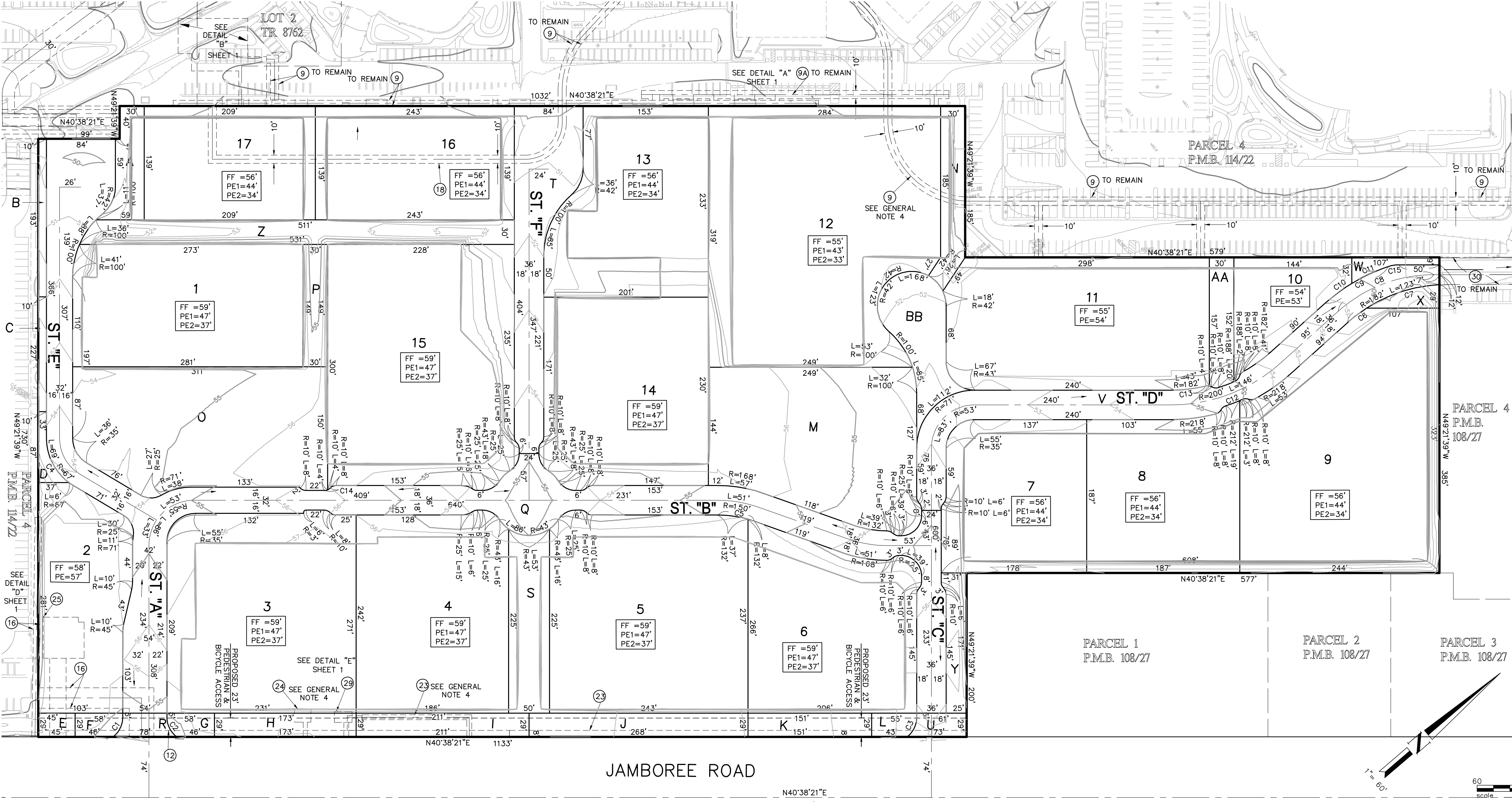
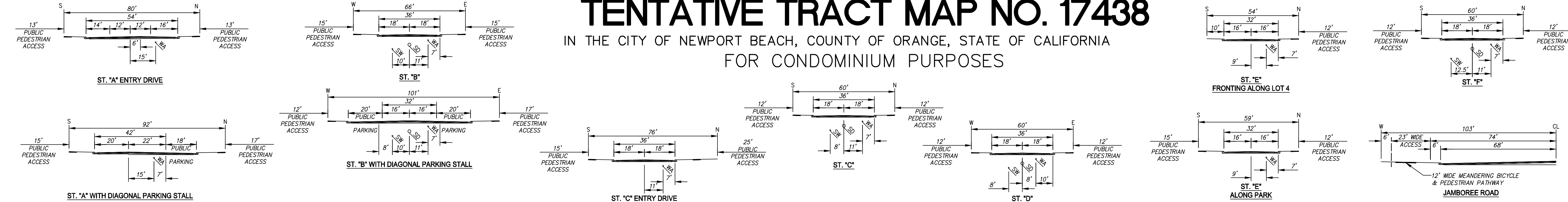

- LEGEND**
- DIRECTION OF DRAINAGE FLOW
 - FF = FINISHED FLOOR
 - PE = PAD ELEVATION
 - PE1 = PAD ELEVATION WITH 1 LEVEL OF PARKING BELOW GRADE
 - PE2 = PAD ELEVATION WITH 2 LEVELS OF PARKING BELOW GRADE
 - TENTATIVE TRACT BOUNDARY
 - PROPOSED LOT LINE
 - PROPOSED BUILDING PAD
 - 56--- PROPOSED GRADE CONTOUR
 - ROADWAY CENTERLINE

| NO. | DESCRIPTION | DATE | BY |
|-----------|-------------|------|----|
| REVISIONS | | | |



Hall & Foreman, Inc.
Engineering • Planning • Surveying
17782 17TH ST, SUITE 200 • TUSTIN, CA 92780-1947 • 714-665-4500

PREPARED UNDER THE SUPERVISION OF: **JOHN C. HOGAN** 11/27/12
DATE

CITY OF NEWPORT BEACH
TENTATIVE TRACT MAP 17438
APN: 445-131-02 & -03
UPTOWN NEWPORT
PA2011-134

FILE NO.
DRAWING NO.
SHEET
2 OF 2

SCALE 1"=60'
DATE 11/28/12
DRAWN BY CS & EO
DESIGNED BY JA & EO

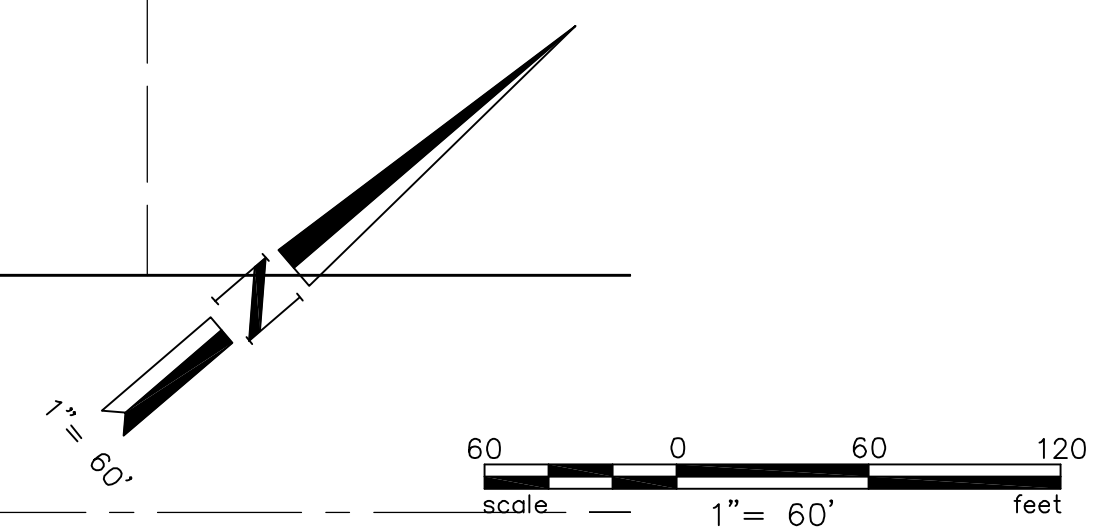

Drawing Name: S:\170288\MapSats\Tentative Map\02-100288T.Mxd Tab: Paper
Last Opened: Nov 28, 2012 - 5:20pm by: Ebone