



CITY OF NEWPORT BEACH

COMMUNITY DEVELOPMENT DEPARTMENT

BUILDING DIVISION

100 Civic Center Drive | P.O. Box 1768 | Newport Beach, CA 92658-8915
www.newportbeachca.gov | (949) 644-3200

Solar PV Standard Plan — Simplified Micro Inverter and ACM Systems for One- and Two-Family Dwellings

SCOPE: Use this plan ONLY for systems using utility-interactive Micro Inverters or AC Modules (ACM) not exceeding a combined system AC inverter output rating of 10 kW, with a maximum of 3 branch circuits, one PV module per inverter and with PV module ISC maximum of 10-A DC, installed on a roof of a one- or two-family dwelling or accessory structure. The photovoltaic system must interconnect to a single-phase AC service panel of 120/240 Vac with service panel bus bar rating of 225 A or less. This plan is not intended for bipolar systems, hybrid systems or systems that utilize storage batteries, charge controllers or trackers. Systems must be in compliance with current California Building Standards Codes and local amendments of the authority having jurisdiction (AHJ). Other articles of the California Electrical Code (CEC) shall apply as specified in section 690.3.

MANUFACTURER'S SPECIFICATION SHEETS MUST BE PROVIDED for proposed inverters, modules, combiner/junction boxes and racking systems. Installation instructions for bonding and grounding equipment shall be provided and local AHJs may require additional details. Listed and labeled equipment shall be installed and used in accordance with any instructions included in the listing or labeling (CEC 110.3). Equipment intended for use with PV system shall be listed or be evaluated for the application and have a field label applied CEC 690.4(B).

Applicant and Site Information

Job Address: _____ Permit #: _____

Contractor/Engineer Name: _____ License # and Class: _____

Signature: _____ Date: _____ Phone Number: _____

1. General Requirements and System Information

Micro inverter

Number of PV modules installed: _____

Number of Micro Inverters installed: _____

AC Module (ACM)

Number of ACMs installed: _____

Note: Listed Alternating-Current Module (ACM) is defined in CEC 690.2 and installed per CEC 690.6

1.1 Number of Branch Circuits, 1, 2 or 3: _____

1.2 Actual number of Micro Inverters or ACMs per branch circuit: 1 _____ 2. _____ 3. _____

1.3 Total AC system power rating = (Total Number of Micro Inverters or ACMs) * (AC inverter power output)
= _____ Watts

1.4 Lowest expected ambient temperature for this plan in Table 1: For -1° to -5° C use 1.12 or for -6° to -10° C use 1.14 correction factors.

1.5 Average ambient high temperature for this plan: = +47° C

Note: For lower expected ambient or higher average ambient high temperatures, use Comprehensive Standard Plan.

2. Microinverter or ACM Information and Ratings

Micro Inverter or ACM Manufacturer: _____

Model: _____

2.1 Rated (continuous) AC output power: _____ Watts

2.2 Nominal AC voltage rating: _____ Volts

2.3 Rated (continuous) AC output current: _____ Amps

If installing ACMs, skip [STEPS 2.4]

2.4 Maximum DC input voltage rating: _____ Volts (limited to 79 V, otherwise use the Comprehensive Standard Plan)

2.5 Maximum AC output overcurrent protection device (OCPD) _____ Amps

2.6 Maximum number of Micro Inverters or ACMs per branch circuit: _____

3. PV Module Information

(If installing ACMs, skip to [STEP 4])

PV Module Manufacturer: _____

Model: _____

Module DC output power under standard test conditions (STC) = _____ Watts

3.1 Module V_{oc} at STC (from module nameplate): _____ Volts

3.2 Module I_{sc} at STC (from module nameplate): _____ Amps

3.3 Adjusted PV Module DC voltage at minimum temperature = [Table 1] _____ [cannot exceed Step 2.4]

Table 1. Module V_{oc} at STC Based on Inverter Maximum DC Input Voltage Derived from CEC 690.7																
Microinverter Max. DC Input [STEP 2.4] (Volts)	34	37	40	43	46	49	52	55	58	61	64	67	70	73	76	79
Max. Module VOC @ STC, 1.12 (-1° to -5° C) Correction Factor (Volts)	30.4	33.0	35.7	38.4	41.1	43.8	46.4	49.1	51.8	54.5	57.1	59.8	62.5	65.2	67.9	70.5
Max. Module VOC @ STC, 1.14 (-6° to -10° C) Correction Factor (Volts)	29.8	32.5	35.1	37.7	40.4	43.0	45.6	48.2	50.9	53.5	56.1	58.8	61.4	64.0	66.7	69.3

4. Branch Circuit Output Information

Fill in [Table 3] to describe the branch circuit inverter output conductor and OCPD size. Use [Table 2] for determining the OCPD and Minimum Conductor size.

Table 2. Branch Circuit OCPD and Minimum Conductor Size*				
Circuit Current (Amps)	Circuit Power (Watts)	OCPD (Amps)	Minimum Conductor Size (AWG)	Minimum Metal Conduit Size for 6 Current Carrying Conductors
12	2880	15	12	¾"
16	3840	20	10	¾"
20	4800	25	8	1"
24	5760	30	8	1"

*CEC 690.8 and 210.19 (A)(1) factored in Table 2, conductors are copper, insulation must be 90° C wet-rated. Table 2 values are based on maximum ambient temperature of 69° C, which includes 22° C adder, exposed to direct sunlight, mounted > 0.5 inches above rooftop, ≤ 6 current carrying conductors (3 circuits) in a circular raceway. Otherwise use Comprehensive Standard Plan.

Table 3. PV Array Configuration Summary			
	Branch 1	Branch 2	Branch 3
Number of Micro Inverters or ACMs [Step 1]			
Selected Conductor Size [Table 2] (AWG)			
Selected Branch and Inverter Output OCPD [Table 2]			

5. Solar Load Center (if used)

5.1 Solar Load Center is to have a bus bar rating not less than 100 Amps. Otherwise use Comprehensive Standard Plan.

5.2 Circuit Power see [STEP 1] = _____ Watts

5.3 Circuit Current = (Circuit Power) / (AC voltage) = _____ Amps

Table 4. Solar Load Center and Total Inverter Output OCPD and Conductor Size**				
Circuit Current (Amps)	Circuit Power (Watts)	OCPD (Amps)	Minimum Conductor Size (AWG)	Minimum Metal Conduit Size
24	5760	30	10	½"
28	6720	35	8	¾"
32	7680	40	8	¾"
36	8640	45	8	¾"
40	9600	50	8	¾"
41.6	≤ 10000	60	6	¾"

**CEC 690.8 and 210.19 (A)(1) factored in Table 4, conductors are copper, insulation must be 90° C wet-rated. Table 4 values are based on maximum ambient temperature of 47° C (no rooftop temperature adder in this calculation), ≤ 3 current carrying conductors in a circular raceway. Otherwise use Comprehensive Standard Plan.

6. Point of Connection to Utility:

6.1 Load Side Connection only! Otherwise use the Comprehensive Standard Plan.

6.2 Is the PV OCPD positioned at the opposite end from input feeder location or main OCPD location?

Yes No (If No, then use 100% row in Table 5)

6.3 Per 705.12(B)(3): (Combined inverter output OCPD size + Main OCPD size) ≤ [bus bar size × (100% or 120%)]

Table 5. Maximum Combined Inverter Output Circuit OCPD										
Bus Bar Size (Amps)	100	125	125	200	200	200	225	225	225	
Main OCPD (Amps)	100	100	125	150	175	200	175	200	225	
Maximum Combined Inverter OCPD with 120% of bus bar rating (Amps)	20	50	25	60†	60†	40	60†	60†	45	
Maximum Combined Inverter OCPD with 100% of bus bar rating (Amps)	0	25	0	50	25	0	50	25	0	

†This plan limits the maximum system size to less than 10 kW, therefore the OCPD size is limited to 60 A. Reduction of Main Breaker is not permitted with this plan.

7. Grounding and Bonding

For Micro Inverters with a grounded DC input, systems must follow the requirements of GEC (CEC 690.47) and EGC (CEC 690.43).

8. Markings

Informational note: ANSI Z535.4 provides guidelines for the design of safety signs and labels for application to products. A phenolic plaque with contrasting colors between the text and background would meet the intent of the code for permanency. No type size is specified, but 20 point (3/8") should be considered the minimum.

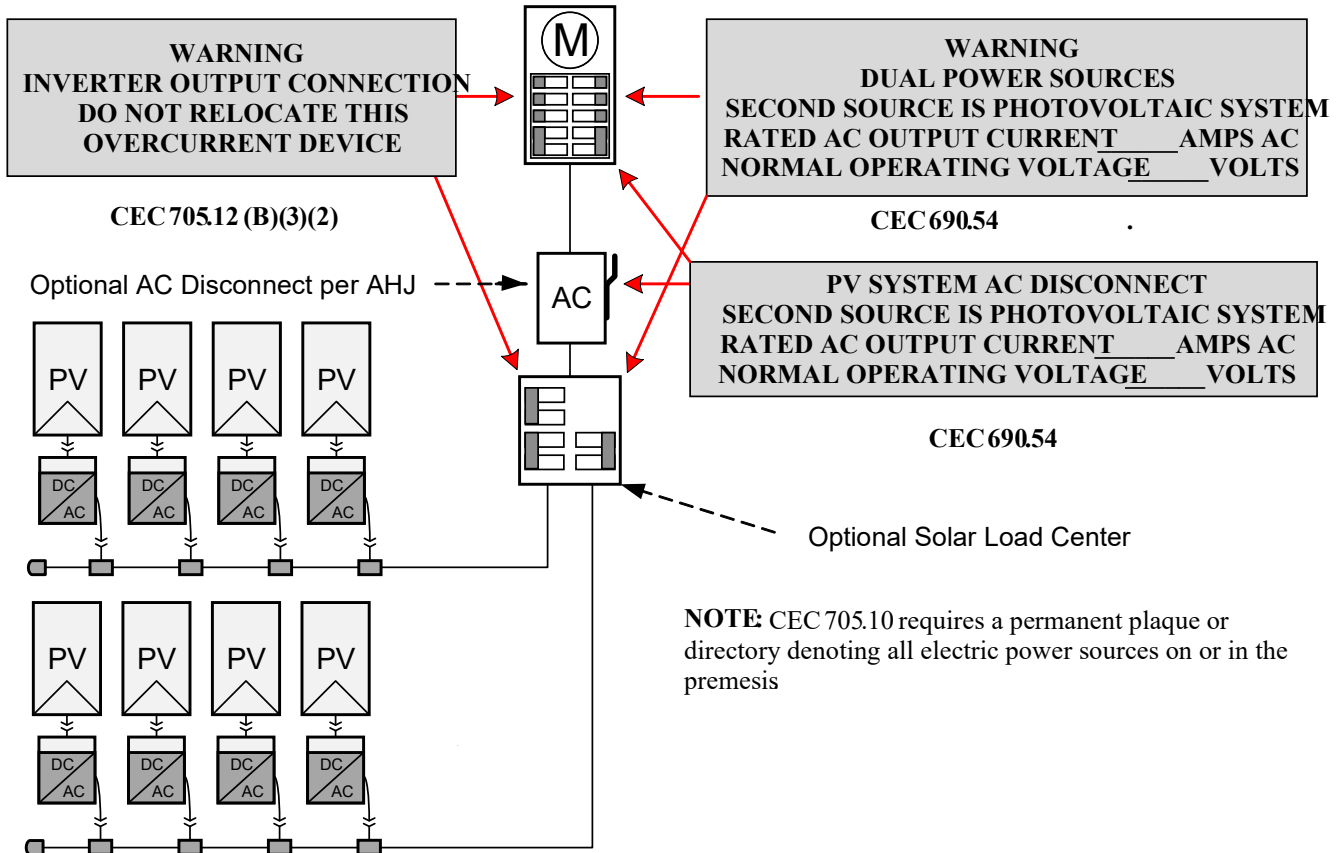

Solar PV Standard Plan — Simplified Micro Inverter Systems for One- and Two-Family Dwellings

9. Single-Inverter Line Diagram

Equipment Schedule	
TAG	DESCRIPTION: (Provide model # if provided)
1	Solar PV Module or ACM:
2	Microinverter (if not ACM):
3	Junction Box (es):
4	Solar Load Center, Yes / No:
5	Performance Meter Yes / No:
6	*Utility External Disconnect Switch Yes / No:
7	Main Electrical Service Panel

DC GEC,
When Required

**Branch Circuit OCPDs
(Table 3)**

Branch 1 OCPD size _____

Branch 2 OCPD size _____

Branch 3 OCPD size _____

Solar Load Center _____

Busbar (Section 5) _____

Main Service Panel OCPDs

Main OCPD size: (table 5)

Combined Inverter Output OCPD: (Table 4)

Main Service Panel Busbar: (Table 5)

Single-Line Diagram for Micro Inverters or ACMs

Check a box for dc system grounding: Grounded, Ungrounded
 For ungrounded dc power systems, EGC is required
 For grounded dc power systems, GEC & EGC are required
 Refer to CEC 250.120 for EGC installation & Table 250.122 for sizing

* Consult with SCE

Conductor, Cable and Conduit Schedule EMT Not Allowed Outside					
TAG	Description and Conductor Type: (Table 3)	Conductor Size	Number of Conductors	Conduit/ Conductor/ Cable Type	Conduit Size
A	Current-Carrying Conductors: (for each branch circuit)				
	EGC:				
	GEC (when required):				
B	Current-Carrying Conductors:				
	EGC:				
	GEC (when required):				

SOLAR PV STANDARD PLAN - SIMPLIFIED

**Micro Inverter and ACM Systems for One- and Two-Family Dwellings
ROOF LAYOUT PLAN**

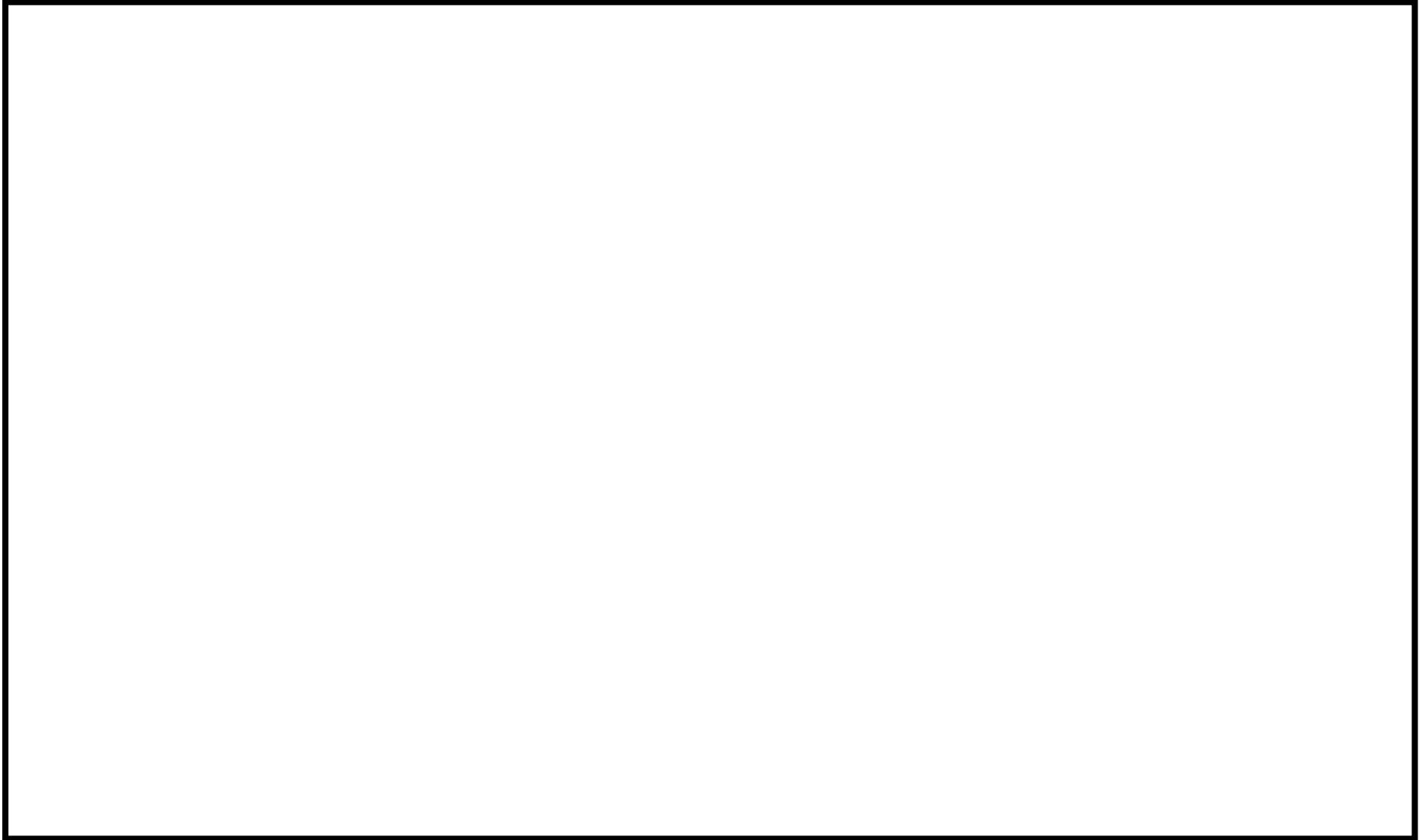

Items required: roof layout of all panels, modules, clear access pathways and approximate locations of electrical disconnecting means and roof access points.