



CITY OF NEWPORT BEACH

COMMUNITY DEVELOPMENT DEPARTMENT BUILDING DIVISION

100 Civic Center Drive | P.O. Box 1768 | Newport Beach, CA 92658-8915
www.newportbeachca.gov | (949) 644-3200

LANDSCAPE REQUIREMENTS

The minimum distance acceptable between finish grade and bottom of treated sill plate shall be as follows:

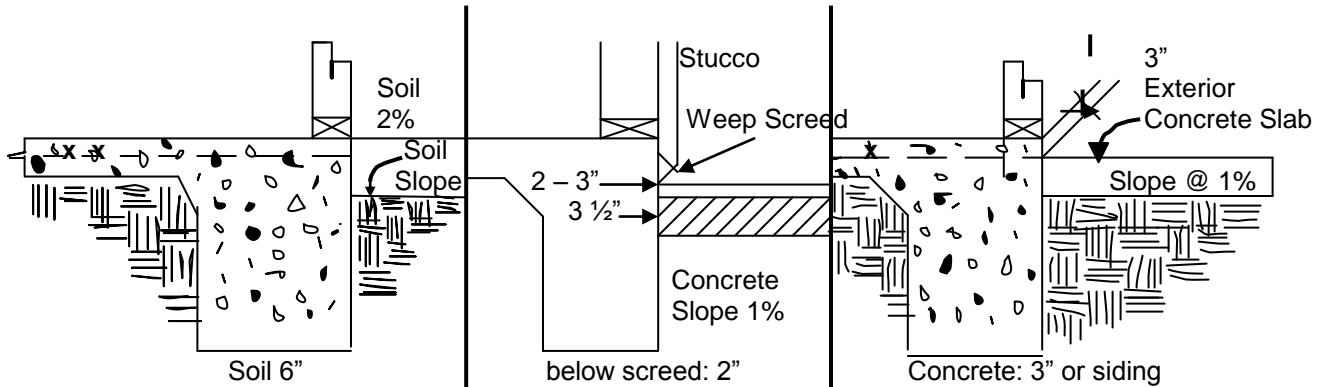

Note: In case the structure is existing and compliance is not feasible, the plan check engineer may make an exception and approve an alternate detail.

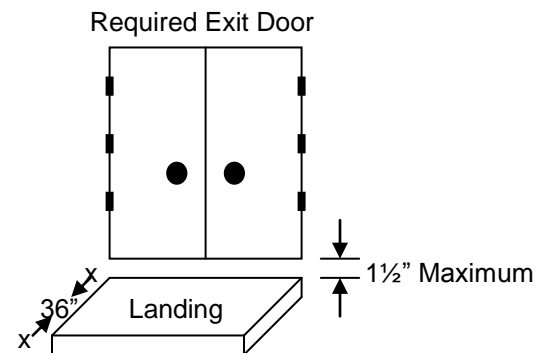
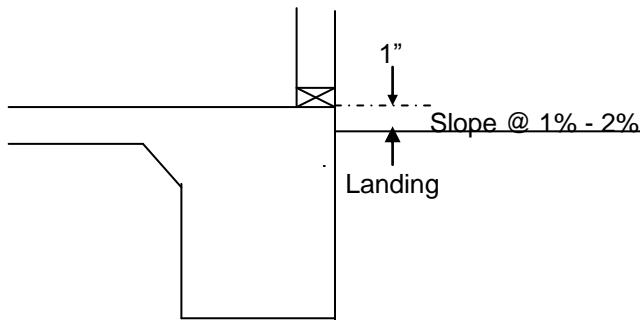

Additional Permits Required:

1. Pool/spa permits cover all electrical and plumbing that is particular to the pool/spa only.
2. An additional plumbing permit is required when other gas outlets are installed, i.e., B-B-Q, Exterior Fireplace, etc.
3. Additional electrical permit is required for lighting or plugs added other than pool related.
4. Drainage permit is required when existing drainage is altered due to pool/spa or landscaping.
5. Sinks are not allowed at freestanding B-B-Qs unless permitted and tied into waste/vent system (not into area drains).