



**CITY OF NEWPORT BEACH**  
**COMMUNITY DEVELOPMENT DEPARTMENT**  
**BUILDING DIVISION**

3300 Newport Boulevard | P.O. Box 1768 | Newport Beach, CA 92658  
[www.newportbeachca.gov](http://www.newportbeachca.gov) | (949) 644-3275

**GRADING/DRAINAGE PLAN REVIEW COMMENTS**

Project Description:

**Project Address:**

**Plan Check No.:**

Permit App. Date:

Permit App. Expires:

Use:

Occupancy:

Const. Type:

CY Cut/Fill:

No. Stories:

Permit Valuation:

Architect/Engineer:

Phone:

Owner/Tenant:

Phone:

Applicant/Contact:

Phone:

**Plan Check Engineer:**

**Phone:**

1<sup>st</sup> Review: (date)

2<sup>nd</sup> Review:  
*Italic comments*

3<sup>rd</sup> Review:  
**By Appointment**

**The project plans were reviewed for compliance with the following codes and standards:**

2010 CBC; 2010 CPC; 2010 CEC; 2010 CMC; 2008 Building Energy Efficiency Standards (BEES);  
 2010 California Green Building Standards Code (CALGreen); & Chapter 15 of the Newport Beach  
 Municipal Code (NBMC).

**The code section references are from the 2010 CBC, unless otherwise stated.**

- *TO EXPEDITE PROJECT APPROVAL:* Please provide a written response indicating how and where each comment was resolved on the plans.
- Resubmit all previously reviewed plans, updated plans and supporting documents with each subsequent review.
- *AFTER 2<sup>nd</sup> PLAN REVIEW:* Please call the plan check engineer listed above to schedule a plan review appointment, to expedite project approval.
- For clarification of any plan review comment, please call the plan check engineer listed above.
- Plan review status is available online at [www.newportbeachca.gov/index.aspx?page=1154](http://www.newportbeachca.gov/index.aspx?page=1154). Project status is also available using the interactive voice response system at 949-644-3255, or by speaking with a permit technician at 949-644-3288 during business hours.

## **GENERAL**

1. Include the following on all plan sheets in the title block:
  - a. Site address,
  - b. Plan preparer's name, address and telephone number,
  - c. Property owner's name, address and telephone number.
2. All permits related to the proposed project shall be issued at the same time, or separate plans and plan review will be required for items not issued with this review. Provide additional permit worksheets for the following:
  - a. Accessory structures, detached patio covers and trellises,
  - b. Detached or free-standing trash enclosures,
  - c. Masonry or concrete fences over 3.5 ft high,
  - d. Retaining walls over 4 ft high from the bottom of the foundation to the top of the wall.
3. Obtain plan review approval from the following:
  - a. Building Department – EMP Plan Review,
  - b. Fire Department,
  - c. Grading Plan Review,
  - d. Planning Department,
  - e. Public Works Department,
  - f. Public Works – Harbor Resources Division,
  - g. Orange County Health Department.
4. All plan sheets shall be signed by the appropriate design professional(s). If the project scope allows plan preparation by other than a licensed individual, such plan preparer shall sign and date all plan sheets. BPCS 5500, et seq.
5. Provide clear, legible drawings, with a print density appropriate for archival and reproduction. Drawing should be 1/4 or 1/8 inch scale. Plan details and text may be of a scale or font size appropriate for the item. Colors shall not be used to show different line types, contrast, or shading. Color photos may not be used to detail architectural or structural elements of the plan.
6. Calculations, reports and other documents shall have an easily removed binding, such as staples or spiral. Permanent edge or glued binding methods are not acceptable.
7. Provide at least two identical plan sets for permit issuance. When multiple plan sets are submitted, or resubmitted, for departmental reviews all sets shall be identical.

## **SURVEY CORRECTIONS:**

8. Provide a site survey, stamped and signed by a State Licensed Land Surveyor or authorized Civil Engineer (License Number below 33,966). Surveyor or engineer shall permanently monument property corners or offsets before starting grading. Provide note on plan.
9. Show north point and scale.
10. Show location and description of all corner monuments.
11. Show and identify all property lines. Dimension length and specify bearing.
12. Show driveway, curb and gutter, and all existing site improvements (structures, walls, planters, stairs, etc.).
13. Identify all finish surface materials.
14. Provide a legend for all symbols used.
15. Locate all trees in public-right-of-way facing or within 20 feet of the subject property; power poles; utility boxes, etc.
16. Show center line of street and dimension width or 1/2 width.
17. Provide an on-site elevation bench mark at a permanent location, in front of the property. For sites within the special flood hazard area and sites on the islands, on the peninsula and in West

Newport Beach, use the actual bench mark elevation as determined by Orange County Vertical Datum (NGVD29 or NAVD88).



18. Provide relative elevations at the following locations:
  - a. All property corners.
  - b. Around existing structure(s) at corners, including corners at jogs of exterior walls.
  - c. At interior finish floor elevations.
  - d. At bottom of all site walls. Indicate wall height.
  - e. At bottom of elevated planters. Indicate planter height.
  - f. At maximum spacing of 25' along the length and width of the property on all sides of an existing structure.
  - g. Elevation contours for sloping sites every one foot elevation change.
  - h. Three elevations (min.) equally spaced in the side yard of adjacent properties.
  - i. Three elevations along the flow line in gutter and alley adjacent to site.

**GRADING CORRECTIONS:**

19. Two wet-signed and stamped sets are required for permit issuance.
20. For projects on a slope, adjacent to a slope, with a basement, or project sites which require remedial grading, soils engineer to review and approve the grading plan, foundation plan, and shoring plan (if applicable) to verify that the design is consistent with the geotechnical report recommendations. Soils engineer to stamp these plans with an approval stamp.
21. Write a note on foundation plan "surveyor to file a corner record or record of survey with the office of county surveyor. Evidence of filing shall be submitted to building inspector prior to foundation inspection."
22. Provide property address on grading plan.
23. Show vicinity map indicating site location.
24. Show name, address, and telephone number of: owner, plan preparer, and geotechnical engineer (if applicable).
25. Show north arrow, plan scale, and legend.
26. Identify ALL property lines by clearly indicating their location.
27. Clearly identify the scope of work. Distinguish between existing hardscape and landscape and new/proposed hardscape and landscape improvements. Show locations of all existing buildings, structures, pools, fences, retaining walls, etc. Show grade elevation on both sides of wall and specify top of wall elevation.
28. Show accurate contours (or spot elevations) indicating the topography of the existing ground. Show locations of all existing slopes on and adjacent to the property.
29. Top of structure footings at habitable space to be above the street gutter flow line elevation by 12" plus 2% the distance from the nearest footing to the gutter. Alternate elevations may be approved, provided it can be demonstrated that required drainage to the point of discharge and away from the structure is provided at all locations on the site. CBC 1805.3.4.
30. Clearly show elevation of adjacent properties and the distance from property lines to adjacent structures.
31. Comply with the minimum slope at the following areas (NBMC 15.10.120 F):

Earth	2.0%
Concrete	0.5%

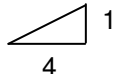
Concrete gutter in paved area	0.2%
Asphalt	1.0%

32. Show finish grades by spot elevations to indicate proper drainage in all areas. Use arrows to indicate direction of drainage.
33. Provide a drainage swale at side yard. Draw a section through swale.
34. Provide a drainage design that prevents entrance of drainage water from the street/alley onto property.
35. Show top of drain elevations and drain invert elevations.
36. Show downspout locations and connection to drain line or discharge location.
37. Design the drainage system to retain concentrated and surface sheet flow water from dry-weather run off and minor rain events within the site. (See Figure A on last page) Sheet flow through lawn area or 15' French drain in crushed rock bed wrapped with filter cloth is acceptable. Locate French drain in the front yard away from foundations.  
(Alternate: Provide hydrology calculations and design retention system to retain  $\frac{3}{4}$ " of rain over 24 hr.)
38. Provide a trench drain at bottom of driveway as shown in Figure B on last page. (Exception: When driveway is less than 10' long, trench drain is not required)
39. Provide specifications for drain lines. Specify diameter 4" (min.) and type of material. The following drain line materials may be used:
  - a. ABS, SDR 35
  - b. ABS, SCHEDULE 40
  - c. PVC, SDR 35
  - d. PVC, Schedule 40
  - e. ADS 3000 with PE glued joints
40. Use UPC Table 11-2 to determine required site drain pipe size (diameter) and slope.
41. The minimum distance between exterior finish grade and bottom of treated sill plate shall be as follows:
  - a. 3" to concrete finish
  - b. 6" to soil
42. For non-residential projects and multi-dwelling projects, specify on permit application the cost of construction of all drainage devices and drainage improvements.
43. Specify volume of cut and fill in cubic yards.
44. Obtain a private drainage easement to drain water over adjacent land not owned by the permittee. Easement must be recorded with the County Recorder's Office.
45. Design drainage to insure water does not drain over the top edge of any slopes.
46. Provide a berm at top of slope. Draw a section through berm. Berm to be 12" high and slopes towards the pad @  1  
4
47. Show top and toe of all slopes and indicate slope ratio.  1 Maximum  
2
48. List the pertinent "Grading Notes" on plans.
49. Where grading is proposed on adjacent property not owned by the permittee, a separate permit is required for that portion under the adjacent address.
50. Show locations and details of subdrain system(s) and outlet for retaining walls on grading plan when subdrain is required by soils report. Subdrain to be piped separately from site drainage or invert in French drain to be higher than the inlet elevation of the nearest drain.

51. Basement slab shall be underlain by a minimum of 4 inches of gravel or crushed stone containing less than 10% passing No. 4 sieve.
52. Provide erosion and siltation control plans.
53. Provide a section showing required grading cut and proximity to property line.
54. Provide building or structure setbacks from top and bottom of slope as shown in CBC, Fig. 1805.3.1. For descending slopes less than 12 feet in height, minimum setback from competent slope face material shall be 4 feet.
55. Top and toe of slope to be setback from the property line per NBMC 15.10.110B, Fig. 1.
56. Provide two copies of soils and foundation investigation report by a registered civil engineer.
57. Soils report shall address the potential of soft or compressible or collapsible or liquefiable soils (Site Classes E and F), and recommend mitigation method if they exist.
58. Soils report shall present seismic site coefficients with supporting documentation.
59. List soils report recommendations on Grading plan
60. Construction with basement or excavation deeper than 3 ft. near the property line:
  - a. The distance from edge of excavation to the property line is less than the depth of excavation. Shoring is required. Provide a shoring plan and calculation prepared by a registered civil engineer.
  - b. Sheet piles are not permitted for shoring due to potential damage to adjacent properties.
  - c. Show all buildings and masonry walls on adjacent property within a distance equal to the depth of the proposed excavation.
  - d. Provide cross-sections at various locations to show excavation details.
  - e. Excavations and shoring shall be made entirely within the project site.
  - f. A Cal-OSHA permit is required for excavations deeper than 5' and for shoring and/or underpinning. Contractor to provide a copy of OSHA permit.
  - g. If bottom of excavation is at or below historical ground water level, submit a dewatering plan and computations by a registered geotechnical engineer.
  - h. Provide additional geotechnical information necessary for dewatering system design, soils report to include the following:
    - i. Borings for soils investigation to extend a minimum of 20 ft. below bottom of proposed excavation.
    - j. Provide sieve analysis and permeability value for each soil formation layer to a depth of 20 ft. below bottom of excavation.
  - k. Write a note on the shoring drawing, "Licensed surveyor to provide monitoring of shoring and improvements on adjacent properties and submit results with a report to the shoring design engineer and to the building inspector on a daily basis during excavation and shoring and weekly basis thereafter. Where dewatering is required, monitoring shall continue until dewatering is stopped."
  - l. Geotechnical engineer to stamp and sign the shoring plan, certifying that the design is in compliance with his soils report recommendation.
  - m. Write a note on drawing: "In lieu of special inspection by Deputy Building Inspector, geotechnical engineer shall provide continuous inspections during shoring and excavation operations and during removal of shoring."
  - n. Provide a description of the process for installing shoring, construction of basement walls, and removal of shoring.

- o. If crushed rock is used to support temporary shoring steel soldier pile, specify method of compaction for gravel fill and method of grouting hole created when steel pile is removed.
- p. Steel soldier pile used as permanent support component of retaining wall shall be protected from earth with 3" concrete cover. Alternate methods of protecting steel flange from corrosion require an application for "Alternate Materials and Methods" with supporting documents and method of protecting material from damage during lagging installation.
- q. Write note on the drawings: "Contractor shall notify adjacent property owners by certified mail 10 days prior to starting the shoring or excavation work."
- r. For slot-cutting method of excavation, provide supporting computations by a registered geotechnical engineer and a drawing showing the location of slots, their width and sequence of slot cuts. Slot cut to be at least 36" away from any property lines and not exceed 5 feet in depth.
- s. Non-cantilevered retaining walls must be shored until the bracing element(s) is in place. Provide a design for wall shoring.
- t. Cantilever shoring supporting hardscape improvements, foundations or swimming pool within a distance of less than half the shoring height shall be designed based on at rest earth pressure.
- u. Depth of embedment of shoring caissons shall not be less than that outlined in CBC Section 1815.5.

#### **DEWATERING SYSTEM CORRECTIONS:**

- 61. Provide the following information on dewatering drawings:
  - a. Well or well point locations.
  - b. Pipe system layout (including valve locations).
  - c. Primary power source. If a generator is used for primary power supply, write a note on drawings stating maximum noise level from proposed generator not to exceed 50 dba on adjoining property.
  - d. Back-up power supply (if any).
  - e. Location of desanding tank.
  - f. Location of property lines and excavation limits.
  - g. Depth of wells or well points (reference to sea level or other datum).
  - h. Diameter of borehole.
  - i. The type of filter media used around wells or well points. Provide sieve analysis graph.
  - j. Size of wellscreen openings (slots) and location of screened portion of well or well point.
  - k. Soil permeability. Dewatering is required during excavation, soil investigation to include boring(s) to a depth of 20' below bottom of proposed excavation for sieve analysis to determine soils permeability.
  - l. Discharge termination point.
  - m. Water meter to measure flow.
  - n. Anticipated draw-down elevation.
  - o. Depth of deepest excavation.
  - p. Method of well removal and abandonment.
- 62. If a well point system is used, provide noise calculation using ARI method to verify noise level from pump not to exceed 50 dba at adjacent property.

63. Public Works approval is required for discharge into storm drain or public way.
64. Provide evidence of approval from State Regional Water Quality Control Board for disposal of ground water.

### **WATER QUALITY CORRECTIONS:**

65. If area of construction site is one or more acres, obtain a general construction NPDES Storm water permit from the State Water Resources Control Board. Tel. (909) 782-4130.
66. This project falls into category checked below. Prepare a Water Quality Management Plan (WQMP) consistent with the model WQMP. (Attached)

### **PRIORITY PROJECTS**

67. Residential development of 10 units or more;
68. Commercial and industrial development greater than 100,000 sq. ft. including parking areas;
69. Automotive repair shop;
70. Restaurant where the land area of development is 5,000 sq. ft. or more including parking area;
71. Hillside development on 10,000 sq. ft. or more which is located on areas with known erosive soil condition or where natural slope is 25% or more;
72. Impervious surface of 2,500 sq. ft. or more located within or directly adjacent to (within 200 ft.) or discharging directly to receiving water within environmentally sensitive areas (San Diego Creek, upper and lower Newport Bay, Buck Gully, Los Trankos, Little Corona del Mar Beach, Crystal Cove State Beach).
73. Parking lot area of 5,000 sq. ft. or more or with 15 or more parking spaces.

### **NON PRIORITY PROJECTS**

74. Require issuance of non-residential plumbing permit.
75. See attached Water Quality Management Plan Correction List.
76. See drawings for additional corrections.

### **ADDITIONAL CORRECTIONS:**

- 77.
- 78.
- 79.

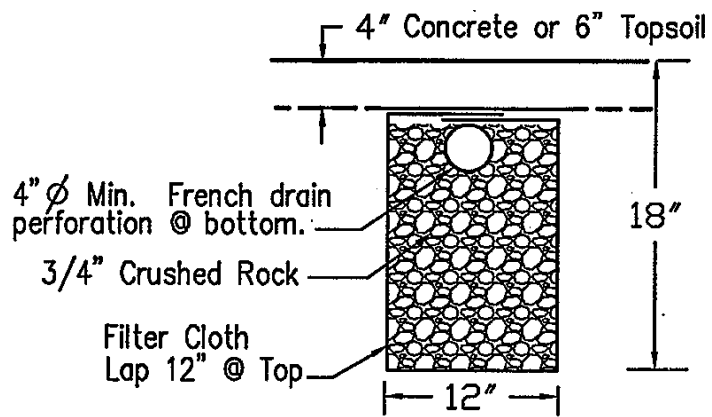

**PERFORATED DRAIN/TRENCH DETAIL**

**Figure A**

DIMENSIONS DETERMINED BY  
GRATE FRAME DIMENSIONS.  
USE FRAME AS A FORM

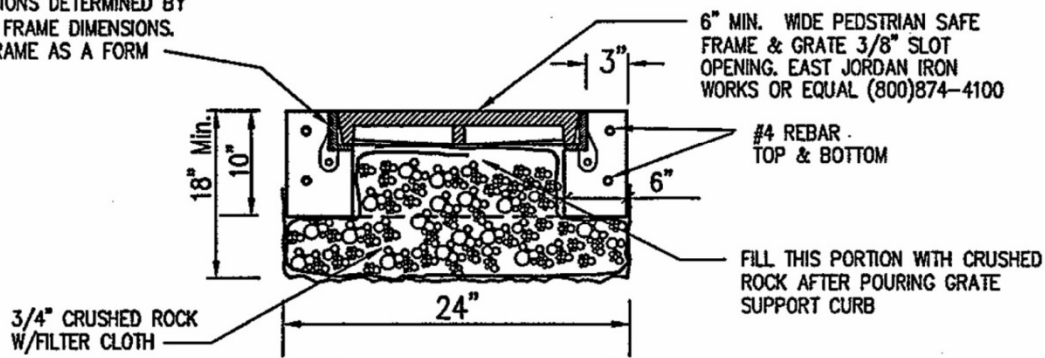

**SECTION E-E**

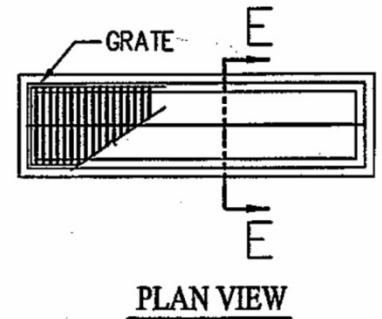

- a- Dig a 24" wide X 18" minimum depth trench
- b- Place filter cloth in the trench. Lap 12" @ top
- c- Fill bottom of the trench with 3/4" crushed rock.
- d- Form and pour perimeter concrete curb.
- e- Fill the rest of the trench with crushed rock to 4" from top of trench.

**BOTTOMLESS TRENCH DRAIN**

**Figure B**