

Profile View: Not To Scale

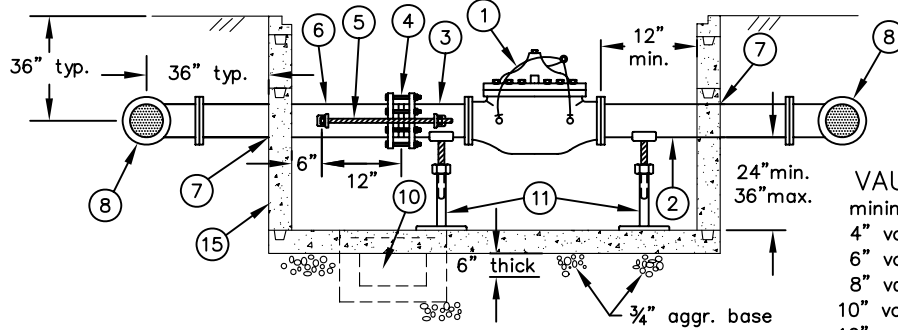

**VAULT SIZING:**  
minimum dimensions:

4" valve	- 48" w x 72" long
6" valve	- 60" w x 72" long
8" valve	- 72" w x 84" long
10" valve	- 72" w x 96" long
12" valve	- 72" w x 108" long

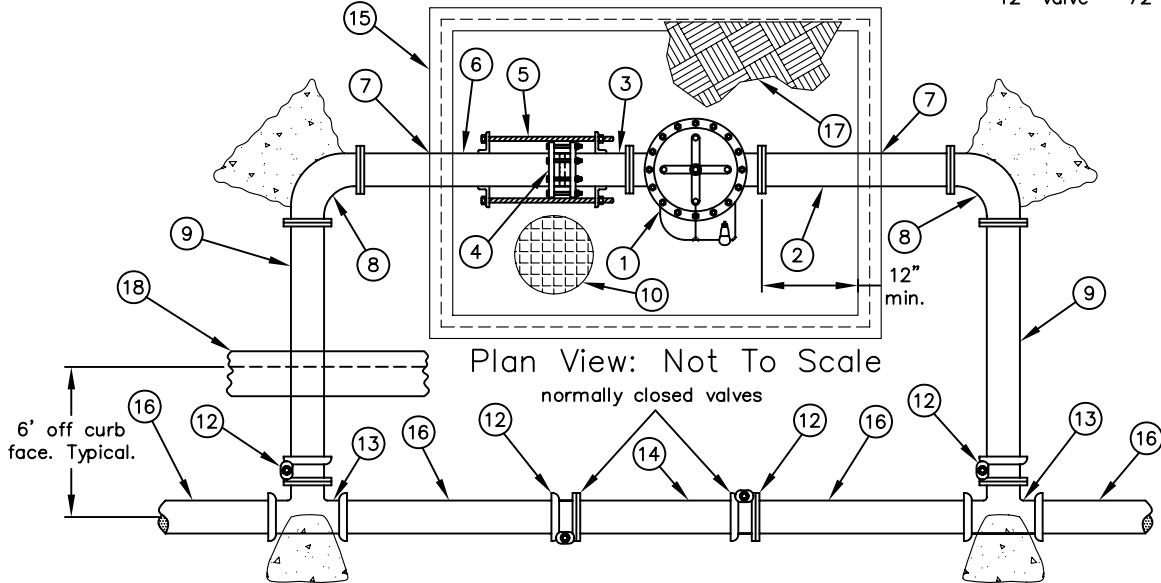

**Construction Notes:**

- ① Clayton Pressure Reducing Valve assembly with stainless steel internal trim & epoxy coated body. Model #90G-1BKCKG.
- ② Class 52, mortar lined, D.I.P. spindle piece (FOE.) 48" long.
- ③ Class 52, mortar lined, D.I.P. spindle piece (FOE.) 12" long. Fabricate with harness lugs.
- ④ Ductile iron flex coupling. Ford, Romac, Dresser or approved equivalent.
- ⑤ Pipe restraint harness assembly. Heavy angle or "U-shaped" ductile iron lugs (preferred) welded to spindle piece. Stainless steel "all-thread" rod. Shackle clamp & eye bolts thru flange may be substituted with special permission of Utilities Supt.
- ⑥ Class 52, mortar lined, D.I.P. spindle piece (FOE.) 54" long. Fabricate with harness lugs.
- ⑦ "Link-Seal" mechanical piping seal in annular space between pipe O.D. & round, sleeve lined, vault opening. Cast sleeve in place with vault.
- ⑧ 90° bend, mortar lined DIP with MJ x FE ends & concrete block.
- ⑨ SDR-14 C-900 PVC pipe or, mortar lined, PE encased, DIP, Class 52.
- ⑩ Round, recessed drain sump with Alhambra Foundry precast grating. 12" minimum depth & diameter.
- ⑪ Adjustable pipe support per STD-522-L, hot DIP galvanize after fabrication and paint.
- ⑫ Resilient seated butterfly valve with "buried service operator". MJ x FE ends.
- ⑬ Mortar lined ductile iron tee. MJ x FE with concrete thrust block.
- ⑭ Class 52, mortar lined, D.I.P. spool piece (FBE.) 36" long. PE encased.
- ⑮ Precast vault w/8" concrete slab floor. Sectional vault may be used in parkway areas. Contact CNB Utilities Dept. for approved manufacturers.
- ⑯ SDR-14 C-900 PVC pipe or, mortar lined, PE encased, DIP, Class 52.
- ⑰ Diamond plate aluminum cover in parkways. Diamond plate stainless steel for traffic areas. Spring assisted, hinged, two piece, locking, cover.
- ⑱ Concrete curb and gutter section, typical. Vaults should be placed in parkway, planter or median areas where practical.

**General Notes:**

1. All above grade piping shall be painted with an Alkyd Enamel paint system consisting of a 2 mil primer coat and two (2) coats of 2 mils (each) high gloss enamel. Color shall be white, blue or red.
2. All below grade ductile iron fittings and piping shall be encased with an 8 mil polyethylene wrap in accord with the AWWA standards.
3. All flange joints shall be connected with type 316 stainless steel fasteners. Mechanical joint shall be joined with either malleable iron or self-weathering CorTen Steel.

CITY OF NEWPORT BEACH  
PUBLIC WORKS DEPARTMENT

**PRESSURE REDUCING  
STATION**

APPROVED:

RCE NO. 36106

PUBLIC WORKS DIRECTOR

Drawn: M. Elias

Scale: N.T.S.

Date: Jan. 2004

F:\USERS\PBW\Shared\CAD\_STD\STD Details\2003 - Std\STD Water

DRAWING NO.

**STD-521-L**